



PMC-5565PIORC Reflective Memory PMC Node Card

Ultra-high-speed, fiber optic network for distributed processing using Reflective Memory

As a longstanding leader in Reflective Memory (RFM) technology, GE Intelligent Platforms understands the demands of real-time networks. We know that certain types of applications require the determinism, implementation simplicity, and lack of software overhead that ubiquitous technologies such as Ethernet can't deliver.

Our PMC-5565PIORC Reflective Memory node card in PMC form factor is engineered specifically to provide highly deterministic, tightly timed performance for a variety of advanced networking applications that need to deterministically move large amounts of data fast and share that data in real time among similar or disparate network nodes.

GE's RFM products are designed to fit into your existing hardware and operating system environment, integrating diverse hardware platforms running different operating systems into a single, shared memory network.

Fast solution to higher performance

The PMC-5565PIORC Reflective Memory node card is well-suited for industrial control applications in which implementation simplicity, a lack of software overhead, and bus structure and operating system independence are key factors, such as:

- Aircraft simulators
- Automated testing systems
- Ship and submarine simulators
- Aluminum rolling mill
- Power plant simulators
- Engine test stands
- Industrial process control
- High-speed data acquisition
- PLCs

PCI Express, PMC, PCI and VME node interface cards are available, and we support a wide variety of operating systems.

Best customer experience

At GE, we understand that there is more to providing solutions than speeds and feeds, and therefore, we complement the performance and practical aspects of our RFM products with long-term product availability, best-in-class domain expertise, and a focus on exceptional customer service. We offer:

- A variety of form factors, operating system support, and configurations for network flexibility
- Ease of integration and migration
- Ease of use
- Long-term availability
- Robust lifecycle management
- Global support and services from GE, the leader in RFM technology

FEATURE	BENEFIT
Low latency, deterministic transfer rates	<ul style="list-style-type: none"> • Achieve predictable, high-performance application deployment
Operating system and bus structure independence	<ul style="list-style-type: none"> • Integrate diverse systems into a single, shared memory network
Transparent data transfers between nodes	<ul style="list-style-type: none"> • Eliminates processor overhead • Delivers higher levels of performance
Error management and detection	<ul style="list-style-type: none"> • Protects against lost dataspace.
RFM network supports up to 256 nodes	<ul style="list-style-type: none"> • Enables the scalability to build the network to fit the application and add more nodes when needed
2.12Gbaud serial connection speed	<ul style="list-style-type: none"> • Transfer data faster between nodes
128 or 256Mbytes of onboard SDRAM	<ul style="list-style-type: none"> • Share large amounts of data



PMC-5565PIORC – Reflective Memory PMC Node Card

Specifications

RAM

- 128 or 256 MByte

Transfer Specifications

- 43 MByte/s (single longword accesses) to 170 MByte/s (64 byte bursts) non-redundant transfer rate
- 20 MByte/s (single longword accesses) to 87 MByte/s (64 byte bursts) redundant transfer rate

PCI Transfer Rate

- 132 MByte/s (33MHz/32-bit bus), 264 MByte/s (33 MHz/64-bit bus or 66 MHz/32-bit bus) or 528 MByte/s (66 MHz/64-bit bus) and throttles back to available link data rate as FIFOs begin to fill
- PCI Express transfer rate: 4 lanes at 2.5 Gbit/s

Environmental Specifications

- Operating: 0°C to +65°C, with forced air cooling
- Storage: -40°C to +85°C
- Relative humidity: 20% to 80%, non-condensing

Power Requirements

- 3.3VDC (± 5%), 0.7A typical, 0.9A maximum
- 5VDC (± 5%), 0.7A typical, 0.9A maximum

Mechanical

- Form Factor: PMC
- Weight: 0.15 lbs

Cooling Requirements

- 300LFM

MTBF (Bellcore)

- 1, 307,078 hours

Cables

- Simplex cable up to 820 feet (250 m)
- Duplex cable up to 721 feet (219.7608 m)

Operating Systems Support

- Microsoft® Windows® XP
- Microsoft Windows 7
- Linux®
- VxWorks®
- Solaris®

Compliance

- Designed to meet the European Union (EU) Restriction of Hazardous Substance (RoHS) Directive (2002/95/EC) current revision

CE

- BS EN55024
- BS EN55022, Class A
- IEC61000 4 2
- IEC61000 4 3

European Union

- BS EN55024 (1998 w A1:01 & A2: 03)
- CISPR22, EN55022 (Class A)
- CISPR11, EN55011 (Class A, Group 1)

United States

- FCC Part 15, Subpart B, Section 109, Class A
- CISPR 22 (1997), Class A
- ANSI C63.4 (2003) method

Australia/New Zealand

- AS/NZS CISPR 22 (2002) Class A
- EN55022 (1998) Class A

Block Diagram

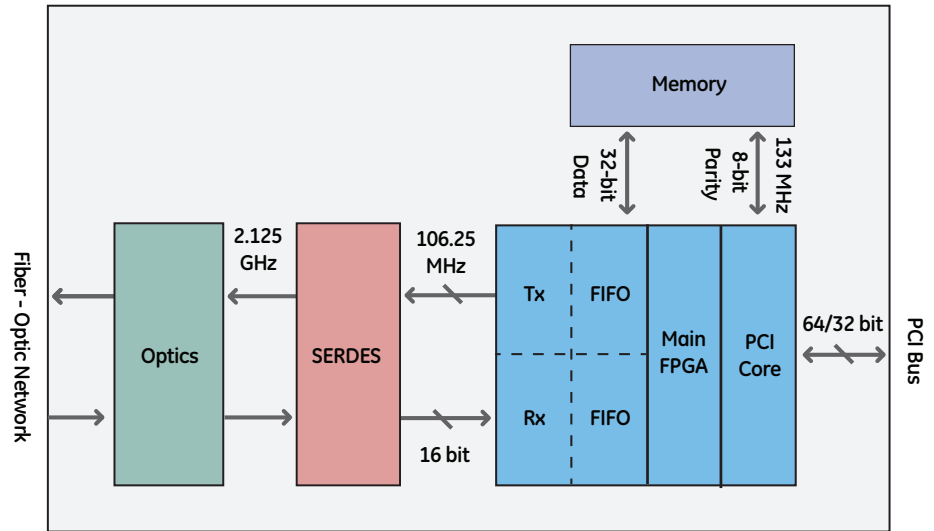

Application Diagram

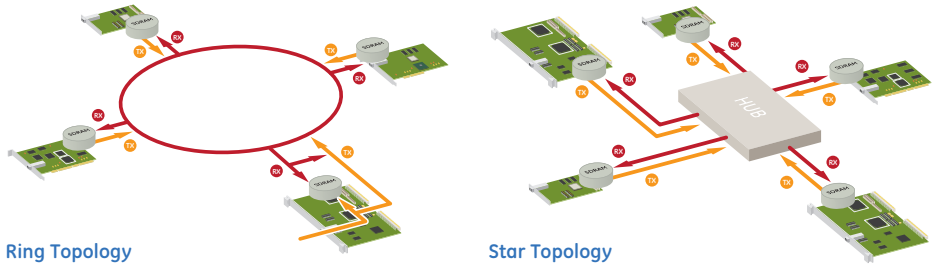

Japan

- VCCI (April 2005) Class A
- CISPR 22 (1997) Class A
- ANSI C63.4 (2003) method

Canada

- ICES 003 Class A
- CISPR 22 (1997) Class A
- ANSI C63.4 (2003) Method

Ordering Information

PMC-5565PIORC-110000	128 MByte Memory, Multimode Transmission
PMC-5565PIORC-111000	128 MByte Memory, Single Mode Transmission
PMC-5565PIORC-210000	256 MByte Memory, Multimode Transmission
PMC-5565PIORC-211000	256 MByte Memory, Single Mode Transmission

GE Intelligent Platforms Contact Information

Americas: **1 800 433 2682** or **1 434 978 5100**

Global regional phone numbers are listed by location on our web site at www.ge-ip.com/contact

www.ge-ip.com

